

Doc No	KHT-22XX SPECIFICATIONS	REV	PAGE	DATE
		A	1 OF 17	2008. 11. 18.

Compact Card Dispenser

WITH Capture Function integrated

Securetech Peripherals, Inc.
336 N. Gaffey Street 2nd Floor
San Pedro, Ca 90731
sales@securetech-corp.com
www.securetech-corp.com

Doc No	KHT-22XX SPECIFICATIONS	REV	PAGE	DATE
		A	3 OF 17	2008. 11. 18.

C O N T E N T S

1. Overview
 2. Features
 3. System Block Diagram
 4. Environmental Requirements
 5. Specification
 6. DC Power Connector
 7. Interface
 8. Technical Drawing
 9. RS232C Interface
 10. Card Status
 11. Card jam.
-
-

Doc No	KHT-22XX SPECIFICATIONS	REV	PAGE	DATE
		A	4 OF 17	2008. 11. 18.

1. Overview

All the processes and operations of KHT-22XX are monitored by its intelligent Microprocessor, which makes itself self-recover function from faulty running.

KHT-22XX has a function to takes an Error card back to the bin. This function is called “Capture“.

2. Features

2.1. Card thickness dispensable can be adjusted easily.

2.2. RS232C Interface

- A. Baud Rate: changeable (9,600 BPS ←19,200BPS)
- B. Can change position of card (one way direction allowed)
- C. With self-diagnosis function.
- D. Easy to control

2.3. KHT-22XX series are applied and integrated to following products and systems;

- Prepaid card vending machine
- ID card issuing machine
- Parking card vending machine
- Payphone card vending machine
- Automatic card issuing machine
- Ticketing vending machine
- And more

2.4. Card Capture Function

- An error card is captured to bin.

2.5. Intelligent monitoring all the process cards empty and card low level warning

function with its own microprocessor

Doc No	KHT-22XX SPECIFICATIONS	REV	PAGE	DATE
		A	5 OF 17	2008. 11. 18.

3. System Block Diagram

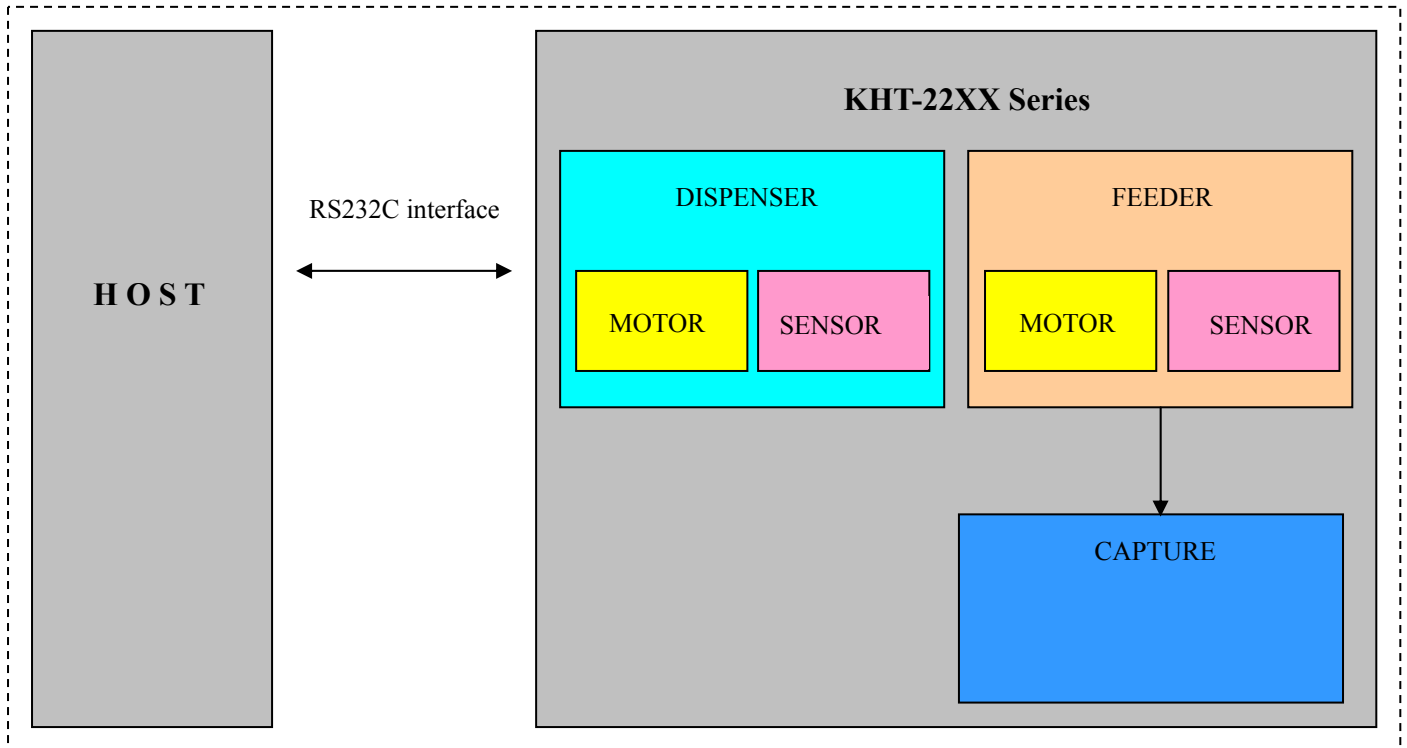

5. Specifications.

5.1. Model.

MODEL	KHT-221X	KHT-222X	KHT-223X	KHT-224X
Dimensions (W x L x H) mm	Refer to Page 8			
Card Dispensing Time (Sec)	1.7	7	1.7	1.7
Max. Card Loading Capacity	100 PCS	200 PCS	300 PCS	500 PCS
	In case of 0.76 mm card			
Card Material	P.V.C			
Max. Card Width, Length	ISO 7810			
Max. Card Thickness	0.76~1.0 mm			
Environmental Requirements	1. Operating Temperature and Humidity: 0~ 40℃, 0~95% RH 2. Conservation Temperature and Humidity: -20~70℃, 0~95% RH			
Power Consumption	1. DC Motor Driver: Output Current 1.5A per channel. 2. Input voltage: DC 24V Only (DC±5%, Min. 2.5A) 3. Standby: 44 mA(+5%).			

Doc No	KHT-22XX SPECIFICATIONS	REV	PAGE	DATE
		A	6 OF 17	2008. 11. 18.

K H T - 2 2 **X** **X**

INTERFACE	FUNCTION	TYPE	CAPACITY	THICKNESS
T: RS-232C	2: DISPENSER	2: SINGLE STACKER	1: 100 PCS 2: 200 PCS 3: 300 PCS 4: 500 PCS	4: 0.76T 5: 0.84T 6: 1.0T

Doc No	KHT-22XX SPECIFICATIONS	REV	PAGE	DATE
		A	7 OF 17	2008. 11. 18.

6. DC Power Connector

6.1. Connector number: J6

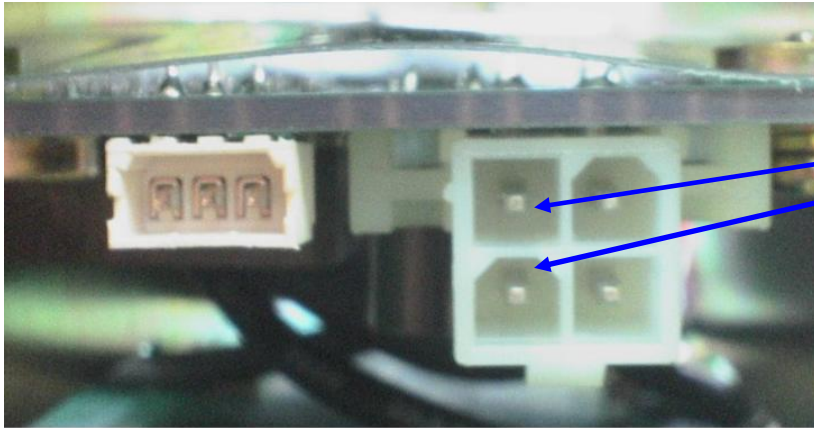

Pin NO.	Signal Name	Direction
1	+24V (GND)	Input
2	Not use	
3	+24V	
4	Not use	

6.2. Connector number: J7 (Option)

Pin NO.	Signal Name	Direction
1 GN	D	Input
2 GN	D	
3 DC	+24V	

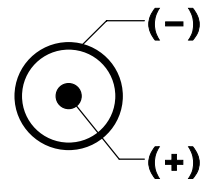

Doc No	KHT-22XX SPECIFICATIONS	REV	PAGE	DATE
		A	8 OF 17	2008. 11. 18.

7. Interface

7.1 RS232C type model

. Interface connector:

When use the KHT-2100's com-cable, connect to twist cable.

When use the user's com-cable, connect to as bellows table

. Connector number: J1

. Connector signal table

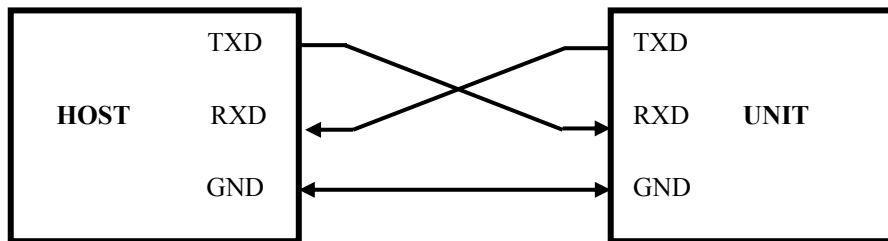

Pin No.	Index	Remark
1 RXD		Receive
2 TXD		Transmit
3 GN	D	S.G

. Communication Method

- Asynchronous, Half duplex.
- Baud Rate: 9600, 19200BPS (Default: 9600BPS)
- Data Length: 8Bits
- Parity: None
- Stop Bit: 1Bit

Doc No	KHT-22XX SPECIFICATIONS	REV	PAGE	DATE
		A	9 OF 17	2008. 11. 18.

8. Technical Drawing

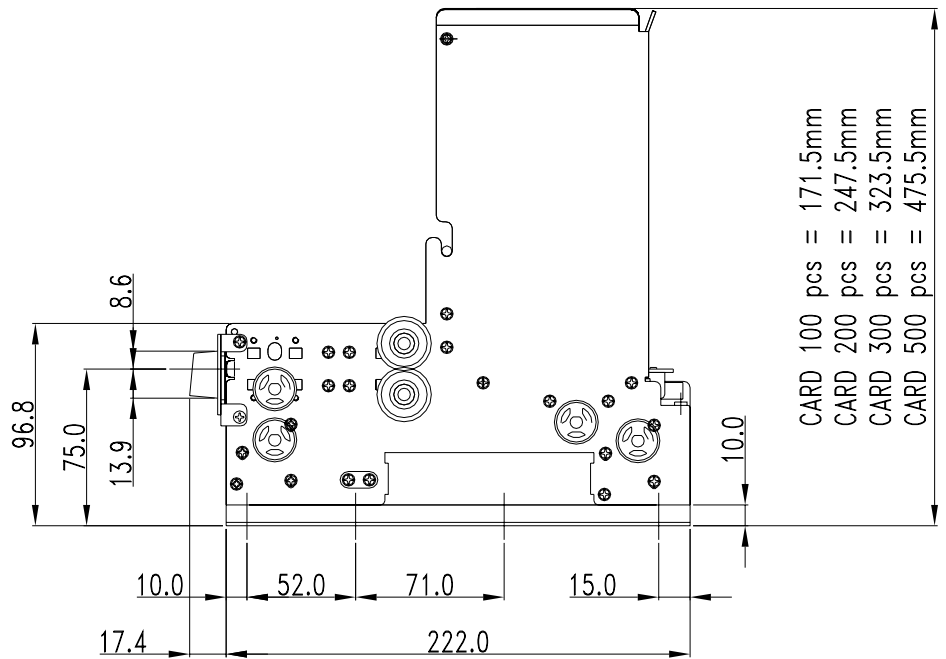
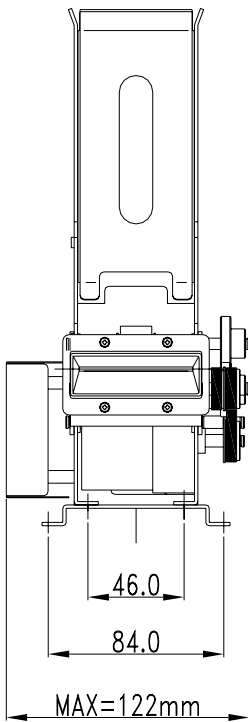
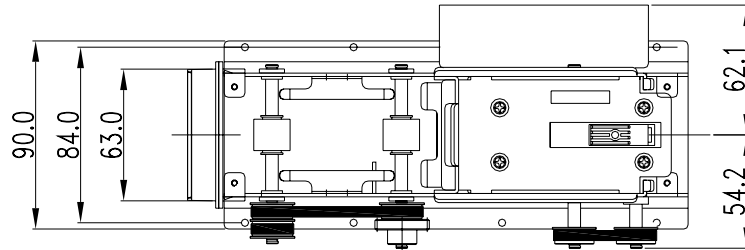

Doc No	KHT-22XX SPECIFICATIONS	REV	PAGE	DATE
		A	10 OF 17	2008. 11. 18.

<Sensor & Motor locations>

Connector No.	Remark
J3 Feed	3 Sensor
J5 Em	pty Sensor
J8 B	ack Sensor
J13 Feed	1 Sensor
J14 Feed	2 Sensor
J9 W	arning Sensor
J11 Feede	r Motor
J12 Dispe	nser Motor

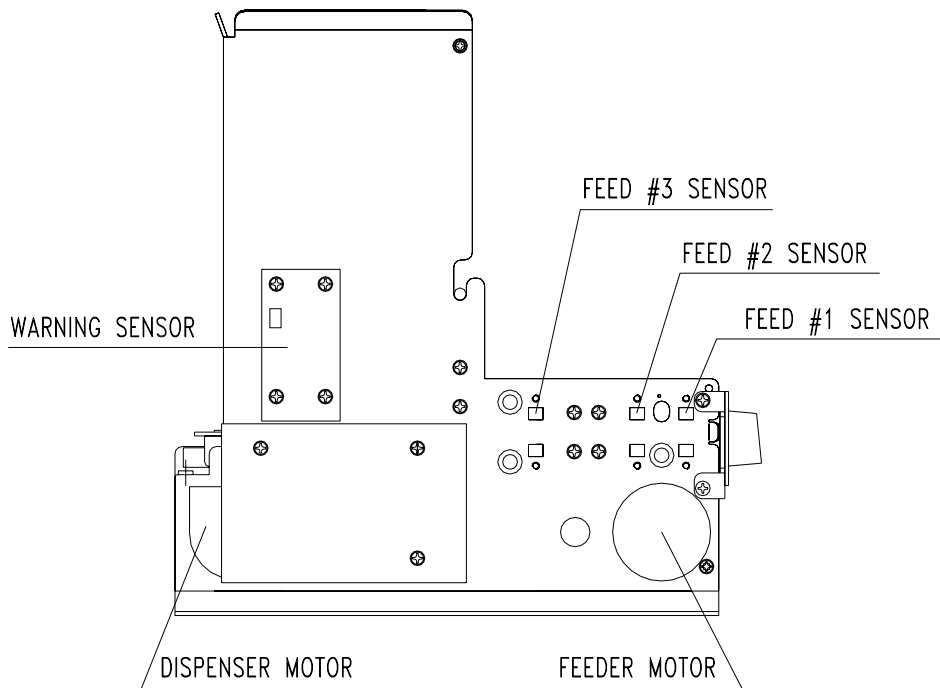
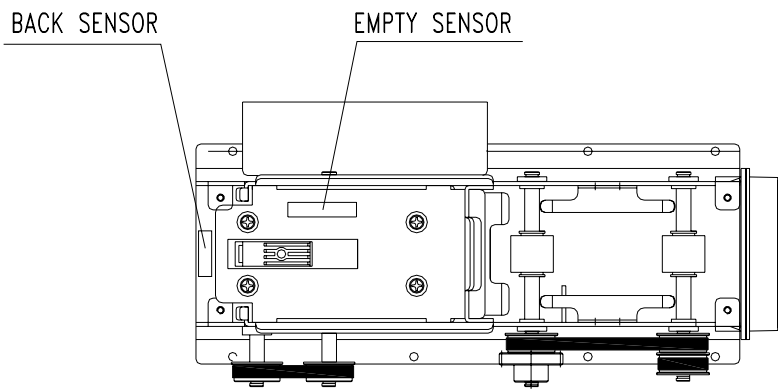

Doc No	KHT-22XX SPECIFICATIONS	REV	PAGE	DATE
		A	11 OF 17	2008. 11. 18.

9. RS232C Interface

9.1. Control Characters

Character	Hex Value	Description
STX	02	Start of Text Character
ETX	03	End of Text Character
EOT	04	End of Text Character
ENQ	05	Enquiry Character
ACK	06	Acknowledge Character
NAK	15	Negative Acknowledge Character
CAN	18	Cancel Character

9.2. Frame Format

Command structure

STX	Command	ETX	BCC
-----	---------	-----	-----

Response structure

STX	Status	S tatus	ETX	BCC
-----	--------	---------	-----	-----

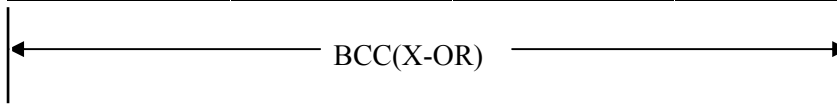

$$BCC = STX \wedge (\text{Command and Status}) \wedge ETX$$

Doc No	KHT-22XX SPECIFICATIONS	REV	PAGE	DATE
		A	12 OF 17	2008. 11. 18.

9.3. Communication Protocol Sequence

CASE 1)



CASE 2) Request Command (0x31)

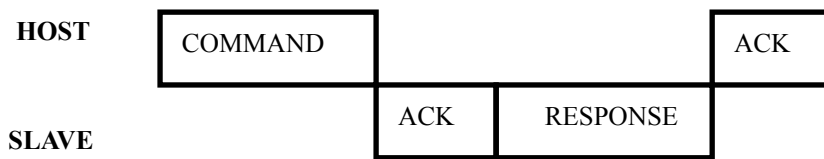

CASE 2-1)

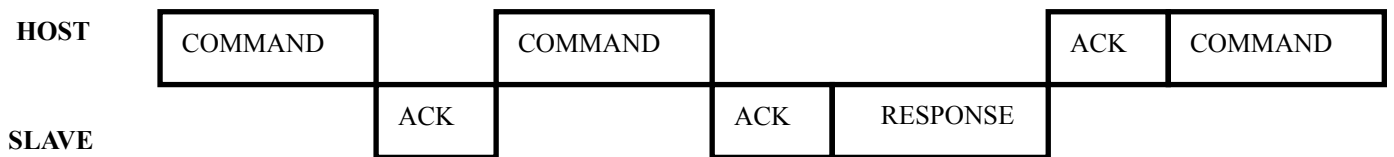

CASE 2-2)



Doc No	KHT-22XX SPECIFICATIONS	REV	PAGE	DATE
		A	13 OF 17	2008. 11. 18.

CASE 2-3)

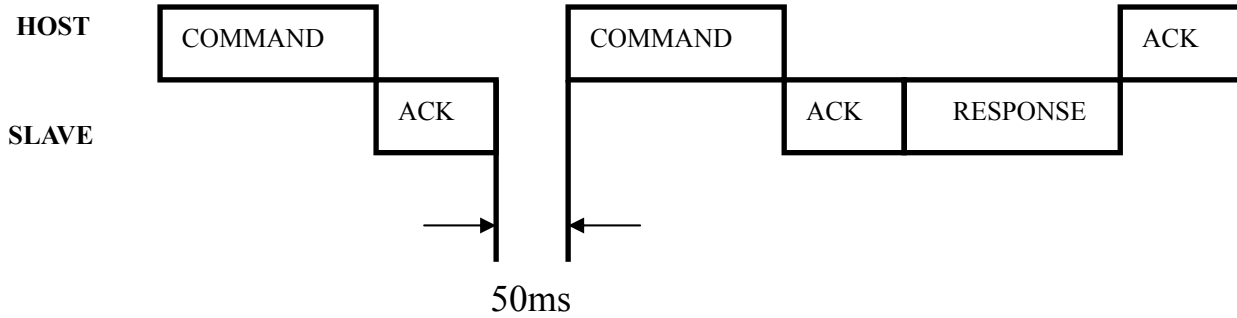

Cf.) To change Baud Rate, send command 50mS after receiving ACK.

10.1. Command Sets List

Item	Command	Description	Note
Clear	0x30	Error Clear	
Request	0x31	Status Request	
Issue	0x40	Issue	
	0x41	Issue	Feeder Standby
Move	0x43	Feed	In
	0x44	Feed	Out
	0x45	Capture	
	0x46	Feed	Stop
	0x47	Feed	Hold
	0x48	Feeder	Standby
	0x60	Ro	m Version
Baud Rate Set	0x50	9600 BPS Setting	Default
	0x51	19200 BPS Setting	

Doc No	KHT-22XX SPECIFICATIONS	REV	PAGE	DATE
		A	14 OF 17	2008. 11. 18.

10.2. Command Details

10.2.1. Clear

: Clear Motor Jam bit of Status Request Command Response

※ Command Packet

STX	Command(0x30)	ETX	BCC
-----	---------------	-----	-----

10.2.2. Status Request

: Host's Request for status of dispenser

※ Command Packet

STX	Command(0x31)	ETX	BCC
-----	---------------	-----	-----

※ Response Packet

STX	Status 1	Status 2	ETX	BCC
-----	----------	----------	-----	-----

※ Status Data Format (Status 1) – cf.) Page 10

7	6	5	4	3	2	1	0
1	0	0	0	0	0	0	0

Data	Status	Remark
0x80	Good	Normal
0x81	Dispenser Jam	Dispenser Motor Jam
0x82	Feed Jam	Feed Motor Jam
0x84	Back Sensor Detection	Back Sensor detect Card
0xc0	Busy	Ready

※ Status Data Format (Status 2) – cf.) Page 10

7	6	5	4	3	2	1	0
1	0	0	0	0	0	0	0

Data	Status	Remark
0x80	Good	Normal
0x81	Card Empty	Dispenser Card Empty
0x82	Warning Sensor Detection.	Warning Sensor detect Card
0x84	Feed1 Sensor Detection	Feed Sensor detect Card
0x88	Feed2 Sensor Detection	
0x90	Feed3 Sensor Detection	

Doc No	KHT-22XX SPECIFICATIONS	REV	PAGE	DATE
		A	15 OF 17	2008. 11. 18.

Stacker Status	Detail
'Stacker Good'	Good.
'Card Warning'	A few Card in the stacker
'Stacker Empty'	No cards in the stacker

-Warning Sensor Setting



Set Value	25pcs	50pcs	75pcs
Set to 25pcs cards	ON	OFF	OFF
Set to 50pcs cards	OFF	ON	OFF
Set to 75pcs cards	OFF	OFF	ON

10.2.3. Issue

: Dispense the card. And completely eject it from the feeder module.

While only feeder module sensors detect the card, if the unit receives “Feed Stop” command, the unit makes the card stop at once.

※ Command Packet

STX	Command(0x40)	ETX	BCC
-----	---------------	-----	-----

10.2.4. Issue Feeder Stand By

: Dispense the card and move it between Feed1 Sensor and Feed3 Sensor.

While only feeder module sensors detect the card, if the unit receives “Feed Stop” command, the unit makes the card stop at once.

※ Command Packet

STX	Command(0x41)	ETX	BCC
-----	---------------	-----	-----

Doc No	KHT-22XX SPECIFICATIONS	REV	PAGE	DATE
		A	16 OF 17	2008. 11. 18.

10.2.5. Feeder Standby

: In the case that the card is present in the feeder module, move the card between Feed1 Sensor and Feed3 Sensor. And then if Sensor1 detect the card, move it between Feed1 Sensor and Feed3 Sensor.

While only feeder module sensors detect the card, if the unit receives “Feed Stop” command, the unit makes the card stop at once.

※ Command Packet

STX	Command(0x48)	ETX	BCC
-----	---------------	-----	-----

10.2.6. Feed In

: In the case that the card is present in the feeder module, move it to the stacker direction.

While only feeder module sensors detect the card, if the unit receives “Feed Stop” command, the unit makes the card stop at once.

※ Command Packet

STX	Command(0x43)	ETX	BCC
-----	---------------	-----	-----

10.2.7. Feed Out

: When the card is present in the feeder module, completely eject the card.

While only feeder module sensors detect the card, if the unit receives “Feed S top” command, the unit makes the card stop at once.

※ Command Packet

STX	Command(0x44)	ETX	BCC
-----	---------------	-----	-----

10.2.8. Capture

: When the card is present in the feeder module, capture the card.

If card is not present in the feeder module, spin the feeder motor in reverse direction during waiting time (1~5 seconds).

And then if Sensor1 detect the card in waiting time, capture it.

While only feeder module sensors detect the card, if the unit receives “Feed S top” command, the unit makes the card stop at once.

※ Command Packet

STX	Command(0x45)	ETX	BCC
-----	---------------	-----	-----

Doc No	KHT-22XX SPECIFICATIONS	REV	PAGE	DATE
		A	17 OF 17	2008. 11. 18.

10.2.9. Feed Stop

: This command stops the card when moving the card in the feeder module.
But that does not concern in the case that the card is not present in the feeder module.

※ Command Packet

STX	Command(0x46)	ETX	BCC
-----	---------------	-----	-----

10.2.10. Feed Hold

: Move the card to the outlet. And stop the card in Feed 1Sensor and Feed2 Sensor.

While only feeder module sensors detect the card, if the unit receives “Feed Stop” command, the unit makes the card stop at once.

※ Command Packet

STX	Command(0x47)	ETX	BCC
-----	---------------	-----	-----

10.2.11. Baud Rate Set

: Baud Rate Setting (After ACK receive, next Command should be transmitted after 50ms)

Case)

※ Command Packet (9600BPS)

STX	Command(0x50)	ETX	BCC
-----	---------------	-----	-----

10.2.12. Status of the card jam and the way to deal with the card jam

- Dispenser Jam

: Can't use all command except Status Request commands
(All jam is canceled and you can use these command, if Clear command is executed.)

- Feeder Jam

: Can't use all command except Status Request commands.
(All jam is canceled and you can use all command, if Clear command is executed)

- In the case that card is detected by Feed1 Sensor, Feed2 Sensor and Feed Sensor 3 at the same time.

: Can't use Issue, Issue Feeder Stand By commands.

But can use the feeder commands such as Capture, Feed In, Feed Out, Feed Hold, Feeder Standby.